

DLC Display Co., Limited

德爾西顯示器有限公司



MODEL No:DLC0350CZG-T

TEL: 86-755-86029824

FAX: 86-755-86029827

E-MAIL: sales@dlcdisplay.com

WEB: www.dlcdisplay.com



Record of Revision

Date	Revision No.	Summary
2010-8-17	1.0	Rev 1.0 was issued

1. Scope

This data sheet is to introduce the specification of DLC0350CZG-T, active matrix TFT module. It is composed of a color TFT-LCD panel, Touch panel, driver ICs, FPC and a backlight unit. The 3.5" display area contains 320 (RGB) x 240 pixels.

2. Application

Digital equipments which need color display, mobile phone, mobile navigator/video systems.

3. General Information

Item	Contents	Unit
Size	3.5	inch
Resolution	320x3(RGB) x 240	/
Technology type	a-si TFT	/
Interface	RGB 24Bit	
Dot pitch	0.219x0.219	mm
Pixel Configuration	R.G.B. Vertical Stripe	
Outline Dimension (W x H x D)	76.90x64.00 x4.2	mm
Active Area	71.20x53.60	mm
Display Mode	Transmissive, Normally White	/
Backlight Type	LED	/
With/ without TP	With Touch panel	

4. Outline Drawing

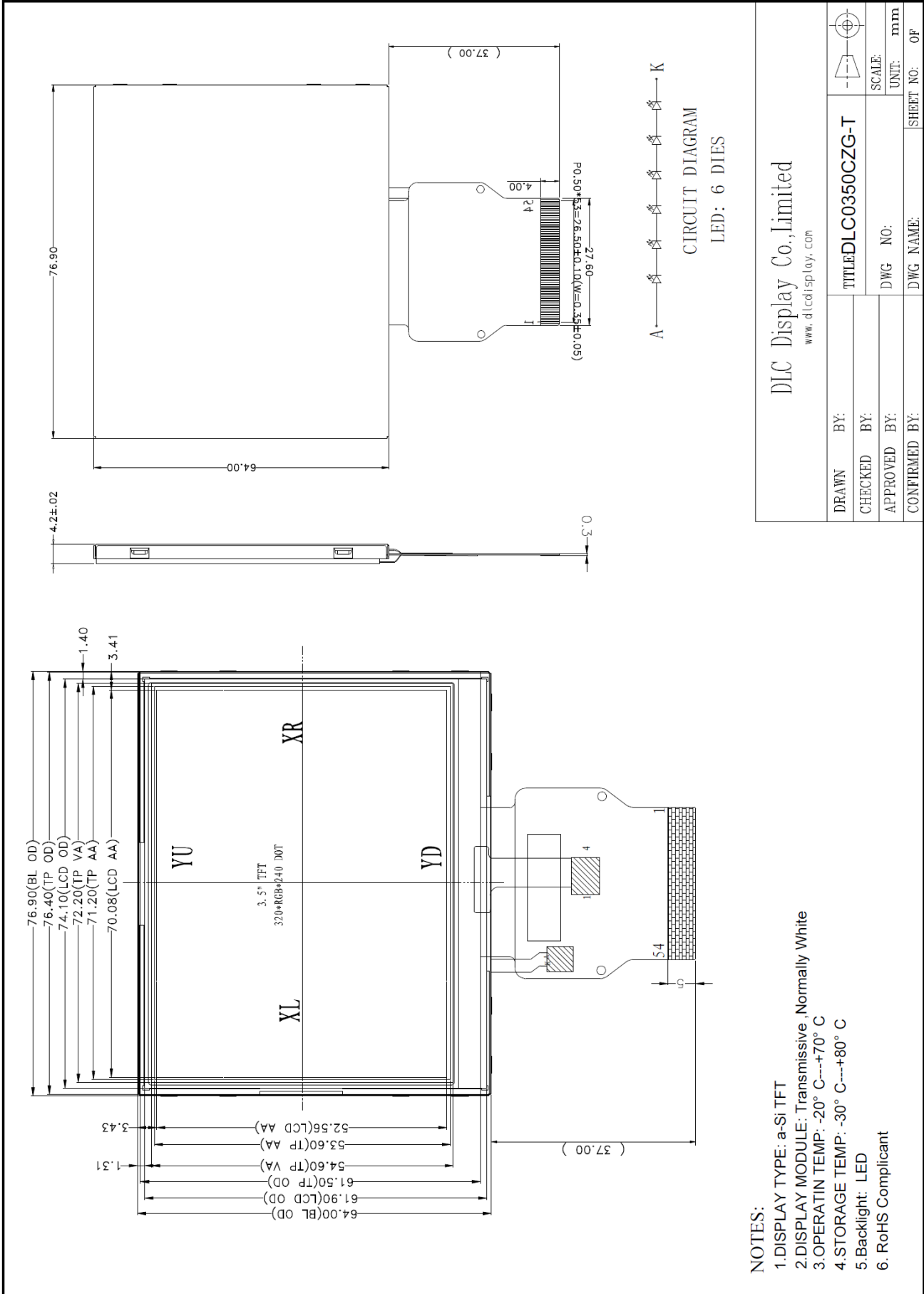

DLC Display Co., Limited www.dlcdisplay.com		TITLE: DLC0350CZG-T	
DRAWN BY:	CHECKED BY:	DWG NO.:	SCALE:
APPROVED BY:	CONFIRMED BY:	DWG NAME:	UNIT: mm
		SHEET NO.:	OF

5. Interface signals

No	Symbol	Description	Remarks
1,2	LED_Cathode	LED_Cathode	
3,4	LED_Anode	LED_Anode	
5	NC	No Connect	
6	RESET	Reset	
7	NC	No Connect	
8	YU	Y_Up	
9	XR	X_Right	
10	YD	Y_Bottom	
11	XL	X_Left	
12	D00	Data 00	
13	D01	Data 01	
14	D02	Data 02	
15	D03	Data 03	
16	D04	Data 04	
17	D05	Data 05	
18	D06	Data 06	
19	D07	Data 07	
20	D08	Data 08	
21	D09	Data 09	
22	D10	Data 10	
23	D11	Data 11	
24	D12	Data 12	
25	D13	Data 13	
26	D14	Data 14	
27	D15	Data 15	
28	D16	Data 16	
29	D17	Data 17	
30	D18	Data 18	
31	D19	Data 19	
32	D20	Data 20	
33	D21	Data 21	
34	D22	Data 22	
35	D23	Data 23	
36	HAYNC	Horizontal Synchronous Signal	
37	VSYNC	Vertical Synchronous Signal	
38	CLK	Data Clock	
39	NC	No Connect	
40	NC	No Connect	
41	VDD	power supply	
42	VDD	power supply	
43	SPENA	Serial port data enable signal	
44	NC	No Connect	
45	NC	No Connect	
46	NC	No Connect	
47	NC	No Connect	
48	NC	No Connect	
49	SPCK	SPI Serial Clock	
50	SPDA	SPI Serial Data Input/output	

51	NC	No Connect	
52	DEN	Data enabling signal	
53	GND	Ground	
54	GND	Ground	

6. Absolute maximum Ratings

6.1. Electrical Absolute max. ratings

Parameter	Symbol	MIN	MAX	Unit	Remark
Power Voltage	VCC	-0.3	5.0	V	

6.2 Environment Conditions

Item	Symbol	MIN	MAX	Unit	Remark
Operating Temperature	TOPR	-20	70	°C	
Storage Temperature	TSTG	-30	80	°C	

6.3 LED Backlight Absolute max. ratings

Item	Symbol	MIN	MAX	Unit	Remark
LED Forward Current	ILED	--	25	mA	For each LED

7 Electrical Specifications

7.1 Electrical characteristics

Ta = 25 °C, VCC=IOVCC= 2.6V to 3.3V, GND=0V.

Item	Symbol	MIN	TYP	MAX	Unit	Remark
Power Supply voltage	VCC	+3.0	+3.3	+3.6	V	
Input Signal Voltage	VIL	0	--	0.3VCC	V	
	VIH	0.7VCC	--	VCC	V	

7.2 LED Backlight

Ta=25°C

Item	Symbol	MIN	TYP	MAX	Unit	Remark
Forward Current	IF	-	20	25	mA	6 LED Serial
Forward Voltage	VF	-	19.8	-	V	

LED CIRCUIT DIAGRAM

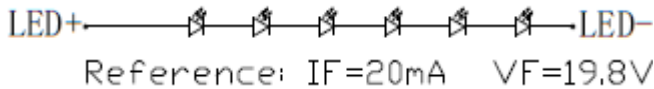

8. Command/AC Timing

8.1 Data input characteristics

Parallel 24-bit RGB Input Timing Table

Parameters	Symbol	Min.	Typ.	Max.	Unit	Conditions
DCLK frequency	fclk	5	9	12	MHz	
VSYNC period time	Tv	277	288	400	Th	
VSYNC display area	Tvd	272			Th	
VSYNC back porch	Tvbp	3	8	31	Th	
VSYNC front porch	Tvfp	2	8	93	Th	
HSYNC period time	Th	520	525	800	DCLK	
HSYNC display area	Thd	480			DCLK	
HSYNC back porch	Thbp	36	40	255	DCLK	
HSYNC front porch	Thfp	4	5	65	DCLK	

Serial 8-bit RGB Input Timing Table

Parameters	Symbol	Min.	Typ.	Max.	Unit	Conditions
DCLK frequency	fclk	24	27	30	MHz	
VSYNC period time	Tv	277	288	400	Th	
VSYNC display area	Tvd	272			Th	
VSYNC back porch	Tvbp	3	8	31	Th	
VSYNC front porch	Tvfp	2	8	93	Th	
HSYNC period time	Th	1560	1716	1900	DCLK	
HSYNC display area	Thd	1440			DCLK	
HSYNC back porch	Thbp	108	120	255	DCLK	
HSYNC front porch	Thfp	12	168	205	DCLK	

Vertical Input Timing

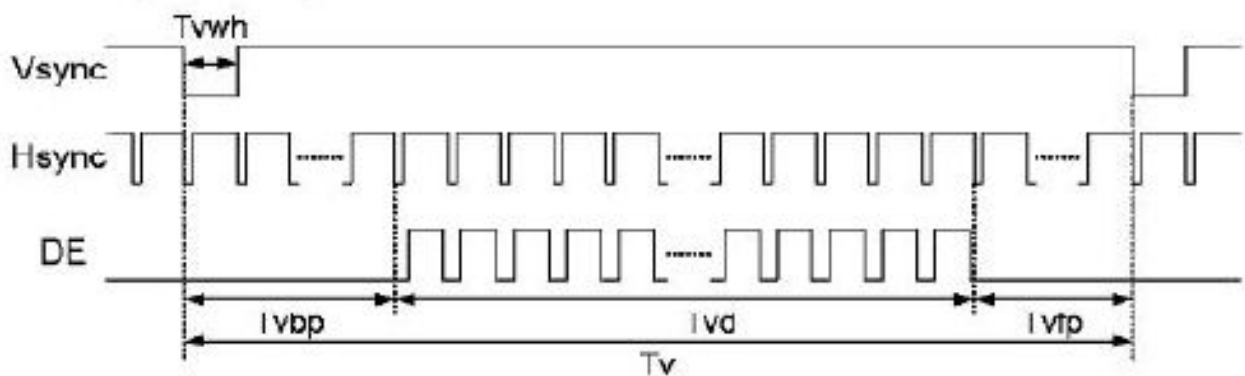

Parallel 24-bit RGB Mode Data Format

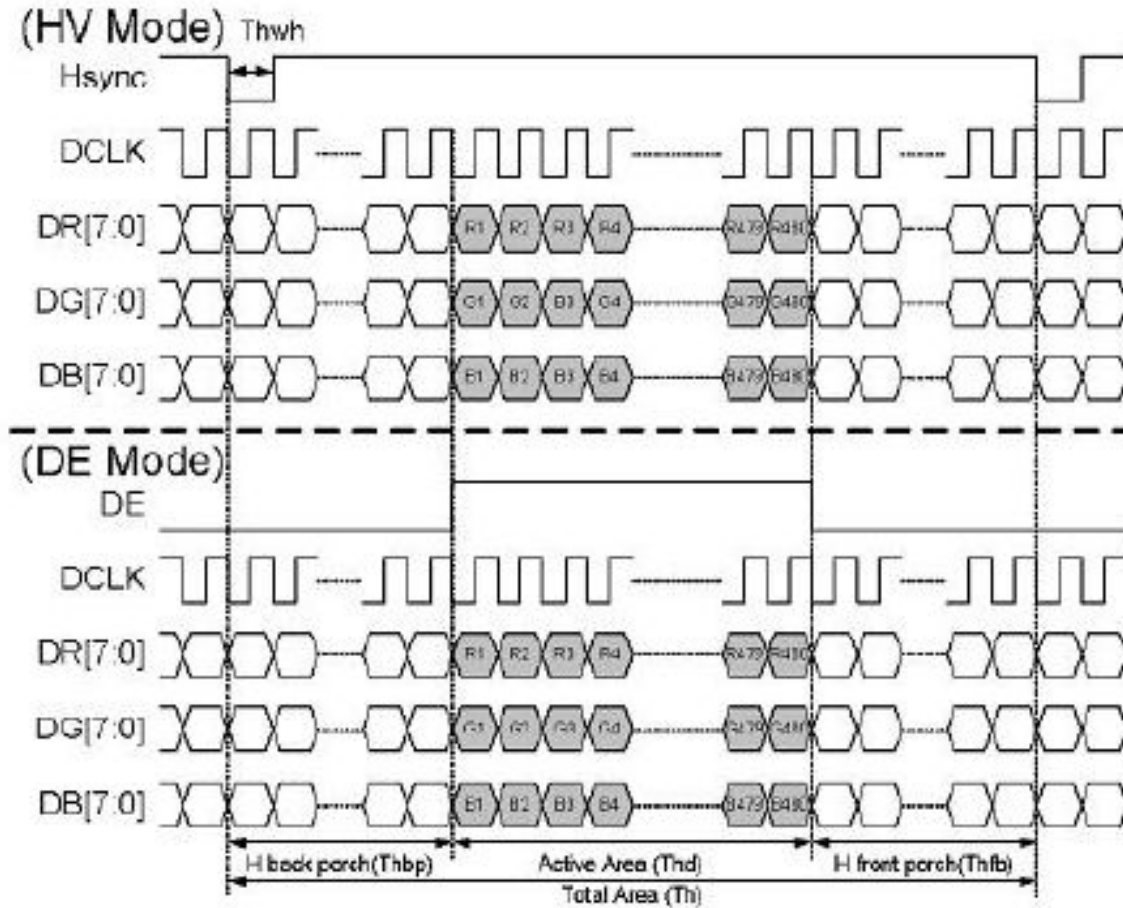

Serial 8-bit RGB Mode Data Format

(HV Mode)

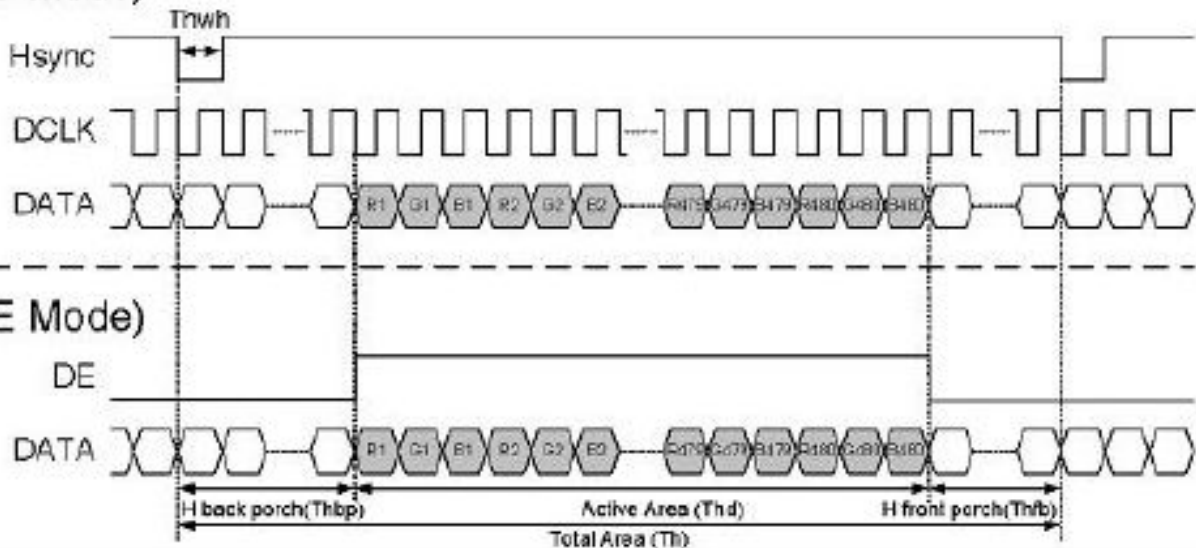

8.2 POWER ON/OFF SEQUENCE

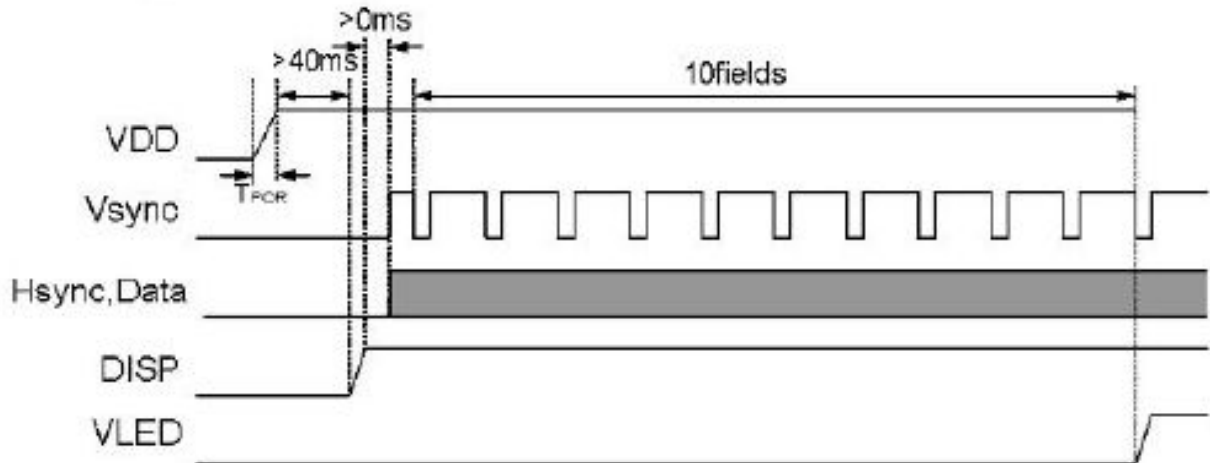
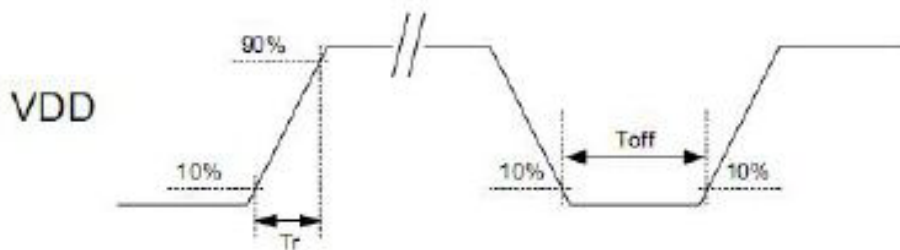
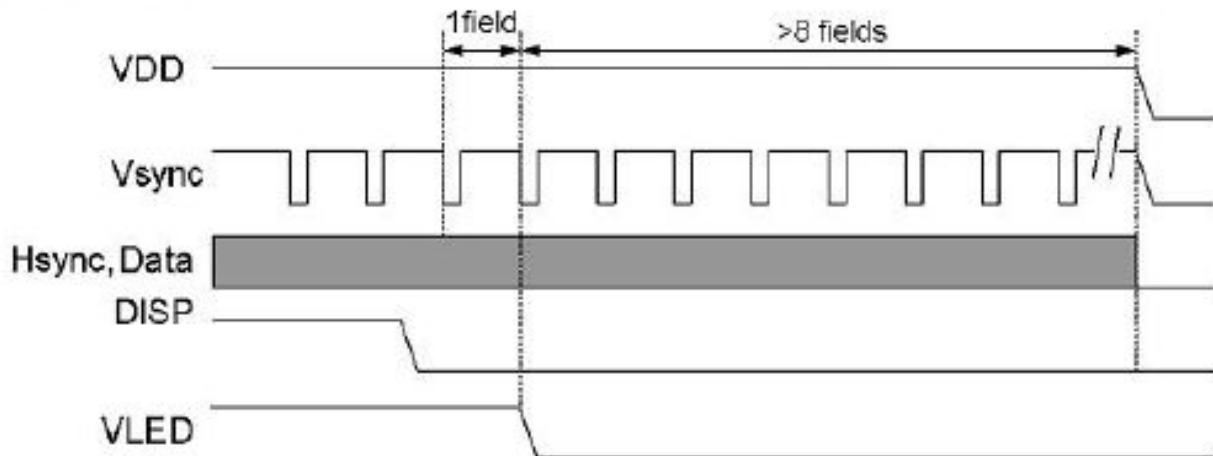
Power On Sequence

Power Off Sequence

VDD power input timing

Notes:

- Data include R0~R7, G0~G7, B0~B7, HSD, VSD, DCLK, DE
- Power on sequence: VDD → DISP → Data → V_{LED}
- Power off sequence: DISP → V_{LED} → Data → VDD
- VDD power input timing: $0.5ms < T_r < 10ms$; $T_{off} > 500ms$

9. Optical Specification

Item	Symbol	Condition	Min	Typ.	Max.	Unit	Remark		
Contrast Ratio	CR	$\theta=0^\circ$	-	370	-		Note1 Note2		
Response Time	Ton	25°C	-	10	20	ms	Note1		
	/ off			15	20	ms	Note3		
View Angles	θT	$CR \geq 10$		50	-	Degree	Note 4		
	θB			70	-				
	θL			70	-				
	θR			70	-				
Chromaticity	White	Brightness is on	Typ-0.05	Typ+0.05			Note5, Note1		
								x	0.311
	y							0.353	
	Red							x	0.636
								y	0.350
	Green							x	0.311
								y	0.551
	Blue							x	0.134
y		0.151							
NSTC	S		-	55		%	Note5		
Luminance	L		-	260	-	cd/m ²	Note1 Note6		
Uniformity	U		75	80	-	%	Note1 Note7		

Test Conditions: $I_F=20\text{mA}$, $V_F=19.8\text{V}$, the ambient temperature is 25°C.

Note 1: Definition of optical measurement system.

Temperature = 25°C(±3°C)

LED back-light: ON, Environment brightness < 150 lx

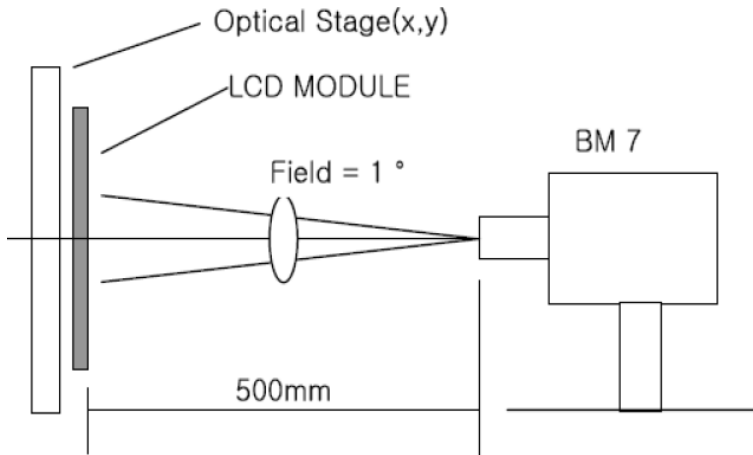

Note 2: Contrast ratio is defined as follow:

$$\text{Contrast Ratio} = \frac{\text{Surface Luminance with all white pixels}}{\text{Surface Luminance with all black pixels}}$$

Note 3: Response time is defined as follow:

Response time is the time required for the display to transition from black to white (Rise Time, T_r) and from white to black(Decay Time, T_f).

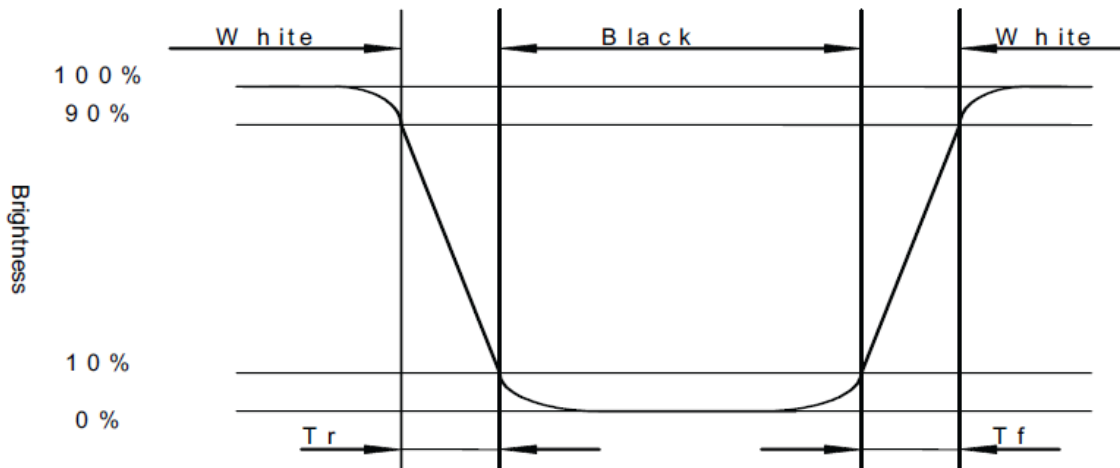

Note 4: Viewing angle range is defined as follow:

Viewing angle is measured at the center point of the LCD.

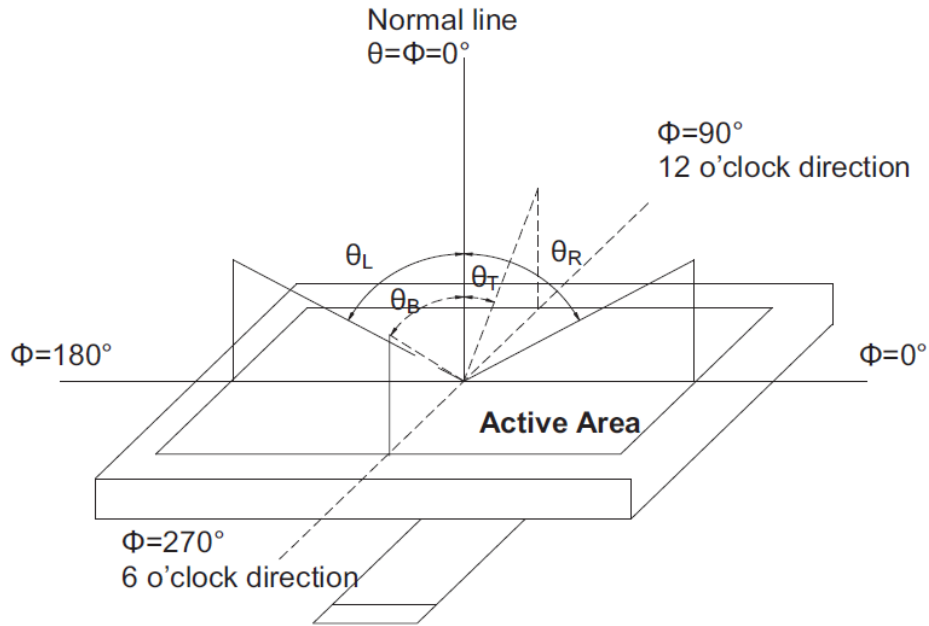

Note 5: Color chromaticity is defined as follow: (CIE1931)

Color coordinates measured at center point of LCD.

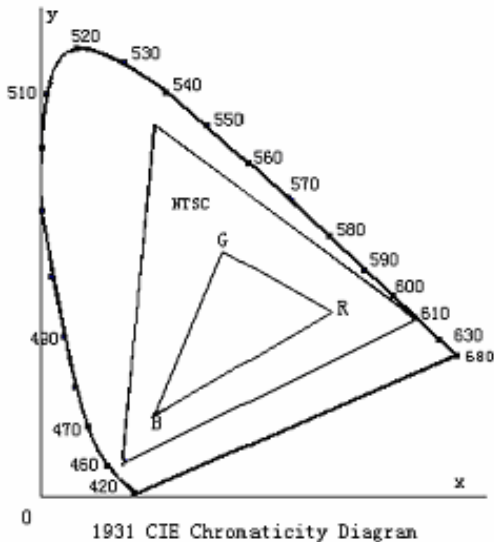

$$S = \frac{\text{area of RGB triangle}}{\text{area of NTSC triangle}} \times 100\%$$

Note 6: Luminance is defined as follow:

Luminance is defined as the brightness of all pixels “White” at the center of display area on optimum contrast

Note 7: Definition of Luminance Uniformity

Active area is divided into 9 measuring areas (Refer Fig. 2). Every measuring point is placed at the center of each measuring area.

Luminance Uniformity (U) = L_{min} / L_{max}

L-----Active area length W----- Active area width

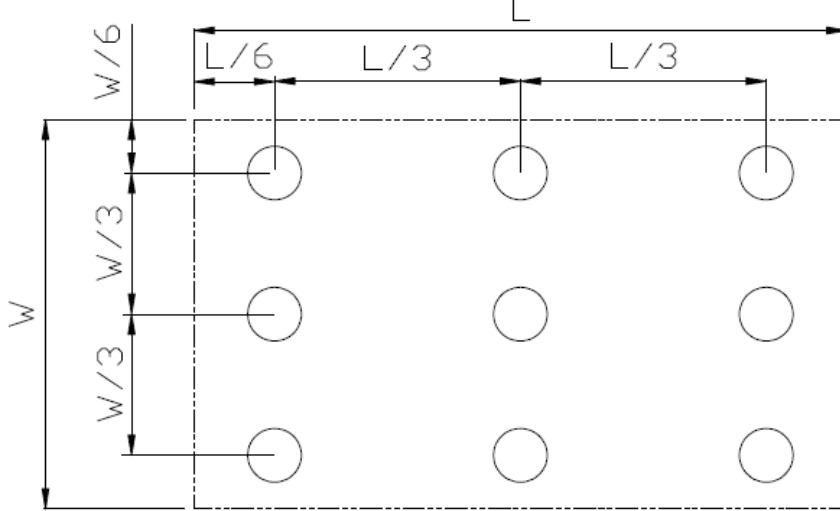

10. Environmental / Reliability Tests

No	Test Item	Condition	Judgment criteria
1	High Temp Operation	Ts=+70°C, 120hrs	Per table in below
2	Low Temp Operation	Ta=-20°C, 120hrs	Per table in below
3	High Temp Storage	Ta=+80°C, 120hrs	Per table in below
4	Low Temp Storage	Ta=-30°C, 120hrs	Per table in below
5	High Temp & High Humidity Storage	Ta=+40°C, 90% RH 120 hours	Per table in below (polarizer discoloration is excluded)
6	Thermal Shock (Non-operation)	-30°C 30 min~+80°C 30 min, Change time:5min, 10 Cycles	Per table in below
7	ESD (Operation)	C=150pF, R=330Ω, 5points/panel Air:±8KV, 5times; Contact:±4KV, 5 times;	Per table in below
8	Vibration (Non-operation)	Frequency range:10~55Hz, Stroke:1.5mm Sweep:10Hz~55Hz~10Hz 2 hours for each direction of X.Y.Z.	Per table in below
9	Shock (Non-operation)	60G 6ms, ±X,±Y,±Z 3times, for each direction	Per table in below
10	Package Drop Test	Height:80 cm, 1 corner, 3 edges, 6 surfaces	Per table in below

INSPECTION	CRITERION(after test)
Appearance	No Crack on the FPC, on the LCD Panel
Alignment of LCD Panel	No Bubbles in the LCD Panel No other Defects of Alignment in Active area
Electrical current	Within device specifications
Function / Display	No Broken Circuit, No Short Circuit or No Black line No Other Defects of Display

11. Precautions for Use of LCD Modules

11.1 Safety

The liquid crystal in the LCD is poisonous. Do not put it in your mouth. If the liquid crystal touches your skin or clothes, wash it off immediately using soap and water.

11.2 Handling

- A. The LCD and touch panel is made of plate glass. Do not subject the panel to mechanical shock or to excessive force on its surface.
- B. Do not handle the product by holding the flexible pattern portion in order to assure the reliability
- C. Transparency is an important factor for the touch panel. Please wear clear finger sacks, gloves and mask to protect the touch panel from finger print or stain and also hold the portion outside the view area when handling the touch panel.
- D. Provide a space so that the panel does not come into contact with other components.
- E. To protect the product from external force, put a covering lens (acrylic board or similar board) and keep an appropriate gap between them.
- F. Transparent electrodes may be disconnected if the panel is used under environmental conditions where dew condensation occurs.
- G. Property of semiconductor devices may be affected when they are exposed to light, possibly resulting in IC malfunctions.
- H. To prevent such IC malfunctions, your design and mounting layout shall be done in the way that the IC is not exposed to light in actual use.

11.3 Static Electricity

- A. Ground soldering iron tips, tools and testers when they are in operation.
- B. Ground your body when handling the products.
- C. Power on the LCD module before applying the voltage to the input terminals.
- D. Do not apply voltage which exceeds the absolute maximum rating.
- E. Store the products in an anti-electrostatic bag or container.

11.4 Storage

- A. Store the products in a dark place at $+25^{\circ}\text{C} \pm 10^{\circ}\text{C}$ with low humidity (40% RH to 60% RH). Don't expose to sunlight or fluorescent light.
- B. Storage in a clean environment, free from dust, active gas, and solvent.

11.5 Cleaning

- A. Do not wipe the touch panel with dry cloth, as it may cause scratch.
- B. Wipe off the stain on the product by using soft cloth moistened with ethanol. Do not allow ethanol to get in between the upper film and the bottom glass. It may cause peeling issue or defective operation. Do not use any organic solvent or detergent other than ethanol.

11.6 Cautions for installing and assembling

Bezel edge must be positioned in the area between the Active area and View area. The bezel may press the touch screen and cause activation if the edge touches the active area. A gap of approximately 0.5mm is needed between the bezel and the top electrode. It may cause unexpected activation if the gap is too narrow. There is a tolerance of 0.2 to 0.3mm for the outside dimensions of the touch panel and tail. A gap must be made to absorb the tolerance in the case and connector.

